

US & International explosion hazardous areas

Differences in codes	US NEC 500	IEC (see NEC 505)
<i>EX protection philosophy</i>	Contain explosions.	Prevent & contain explosions.
<i>EX codes writing institutes</i>	NFPA (mostly industry members)	IEC (independent members)
<i>EX codes & regulations</i>	Codes are NOT turned into LAWS	Codes are turned into LAWS
<i>EX codes enforcement</i>	Insurance companies / OSHA	Local Governments
<i>EX code acceptance / coverage</i>	North America, Mexico & China	Worldwide

	Ignitable concentrations of hazardous material are present <i>all of the time.</i>	Ignitable concentrations of hazardous material are present <i>some of the time.</i>	Ignitable concentrations of hazardous material might, but are not likely to exist.
US NEC 500 / IEC	Cl. 1/2/3 - Div. 1*	Cl. 1/2/3 - Div. 1	Cl. 1/2/3 - Div. 2
US NEC 505 / IEC	Zone 0*	Zone 1 / 21	Zone 2 / 22

* Only intrinsically safe electrical equipment may be used in these areas

	US NEC 500 / IEC		US NEC 505 / IEC
Class I: Flammable Gases, Vapors or Liquids	Division 1: (where ignitable concentrations of Flammable Gasses, vapors or liquids are likely to exist <i>all of the time</i> (zone 0) under normal operating conditions.)	Groups: A, B,	Zone 0: (all the time)
	Division 1: (where ignitable concentrations of Flammable Gasses, vapors or liquids are likely to exist <i>some of the time</i> (zone 1) under normal operating conditions.)	Groups: C & D	Zone 1: II C, IIB & IIA, T4 (120oC)(some of the times)
	Division 2: (where ignitable concentrations of Flammable Gasses, vapors or liquids <i>might but are not likely</i> to exist under normal operating conditions.)	Groups: A, B, C & D	Zone 2: II C, IIB & IIA, T4 (120oC)
Class II: Combustible Dusts	Division 1: (where ignitable concentrations of combustible dusts are likely to exist <i>all the time or some of the time</i> under normal operating conditions.)	Groups: E, F&G	Zone 21: IIB & IIA, T4 (120oC) with dust protection
	Division 2: (where ignitable concentrations of combustible dusts <i>might but are not likely to exist</i> under normal operating conditions.)	Groups: E, F&G	Zone 22: II C, IIB & IIA, T4 (120oC) with dust protection
Class III: Ignitable Fibers & materials	Division 1: (where ignitable concentrations of easily ignitable fibers or materials are likely to exist <i>all the time or some of the time</i> under normal operating conditions.)	No groups	Zone 21: IIB & IIA, T4 (120oC) with dust protection
	Division 2: (where ignitable concentrations of easily ignitable fibers or materials <i>might but are not likely to exist</i> under normal operating conditions.)	No groups	Zone 22: II C, IIB & IIA, T4 (120oC) with dust protection

Group designations		
US gas designation	IEC gas designation	Gas description
A	IIC	Acetylene
B		Hydrogen
C	IIB	Ethylene
D	IIA	Propane

Group designations	
US & IEC dust designation	Dust description
E	Metals
F	Coal
G	Grain

EEx Zone 1 explosion proof, Category 2G - 94/9/EG
Protection type: Ex II 2G IIB 120° / PTB 03 ATEX 3038

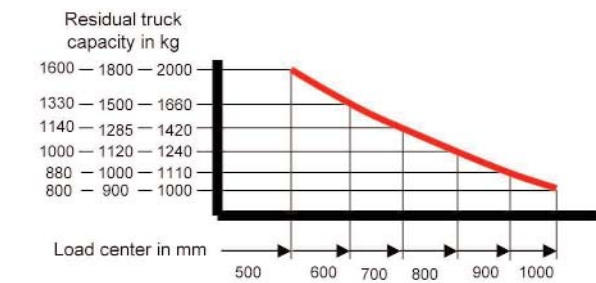
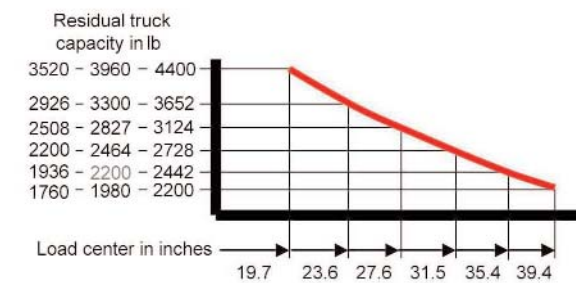
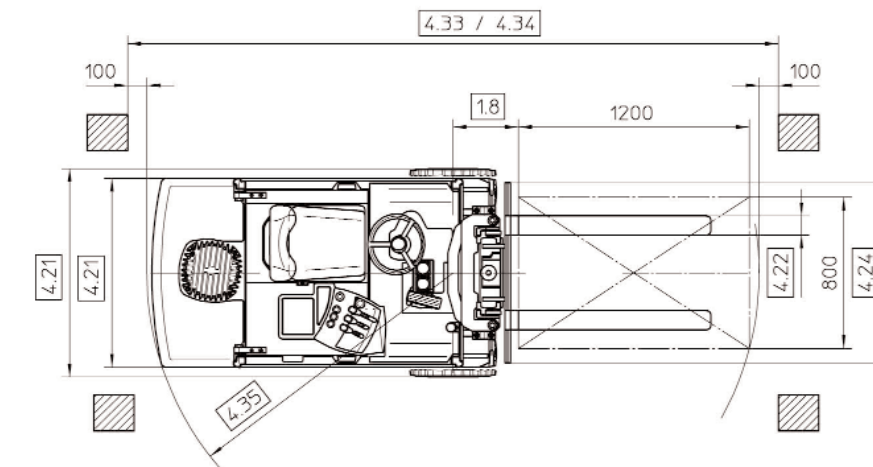
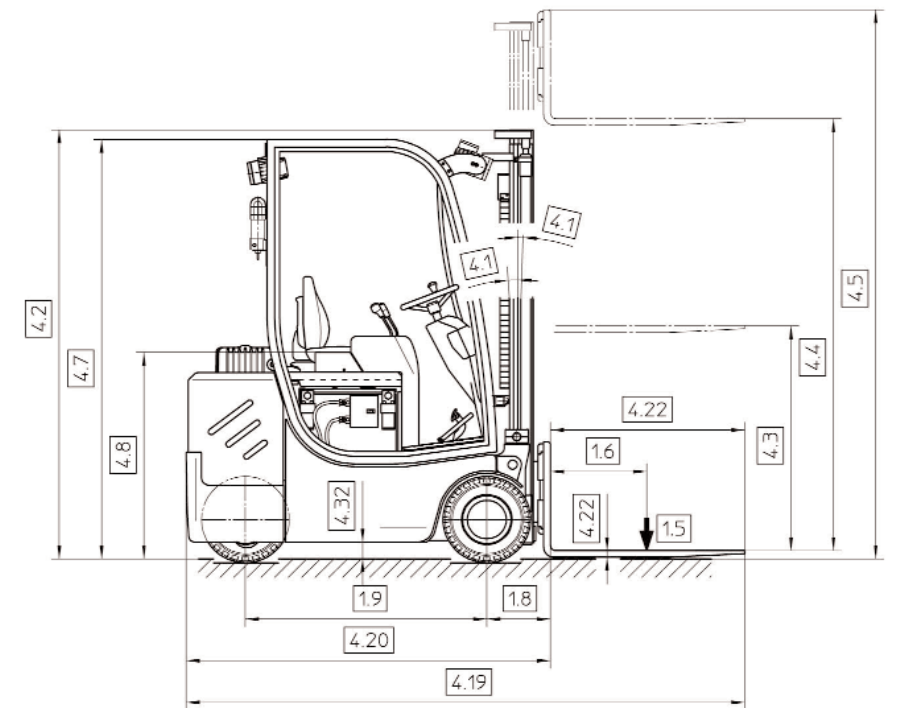

Use our EX forklift truck selector guide at www.sichelschmidt.com

Sichelschmidt Global Sales
105-B West Dewey Avenue
Wharton, NJ 07885
United States



phone: 973-442-7878
fax: 973-442-1874
e-mail: robert_zuiderveld@servo-lift.com
website: www.sichelschmidt.com

EX Electric 3-Wheel Counterbalance Truck M-700-3EEEx/ASM (long wheel base)

EEx Zone 1 explosion proof, Category 2G - 94/9/EG - Protection type: Ex II 2G IIB 120° / PTB 03 ATEX 3038

Description		Truck specifications		
Designations	1.1 Manufacturer	Sichelschmidt	Sichelschmidt	Sichelschmidt
	1.2 Model designation	M-716-3EEEx/ASM	M-718-3EEEx/ASM	M-720-3EEEx/ASM
	1.3 Propulsion	electric	electric	electric
	1.4 Operator position	sit down	sit down	sit down
	1.5 Capacity	3520lb (1600kg)	3960lb (1800kg)	4400lb (2000kg)
	1.6 Load center	19.7" (500mm)	19.7" (500mm)	19.7" (500mm)
	1.8 Load distance (center of the front wheel to the front of the fork shank)	13.6" (346mm) <i>*/**</i>	13.6" (346mm) <i>*/**</i>	13.6" (346mm) <i>*/**</i>
	1.9 Wheel base (center of the front wheel to the center of the rear wheel)	56.5" (1435mm)	56.5" (1435mm)	56.5" (1435mm)
	2.1 Truck weight	8580lb (3900kg) ¹	8866lb (4030kg) ¹	9350lb (4250kg) ¹
Weights	2.2 Axle load WITH maximum capacity load - front / rear	9988/5115lb (4540/950kg) ¹	10956/1870lb (4980/850kg) ¹	11748/2002lb (5340/910kg) ¹
	2.3 Axle load WITHOUT load - front / rear	3960/4620lb (1800/2100kg) ¹	4138/9244lb (1881/2150kg) ¹	4466/4884lb (2030/2220kg) ¹
	2.4 Axle load with extended mast - front / rear	---	---	---
	2.5 Axle load with retracted mast - front / rear	---	---	---
	Wheels & Chassis	3.1 Tire type (Solid rubber / Super elastic (Solid Pn.) / Pneumatic / Poly)	Super-elastic	Super-elastic
3.2 Front wheel dimensions - diameter x width		18 x 7-8	18 x 8-9	18 x 8-9
3.3 Rear wheel dimensions - diameter x width		18 x 7-8	18 x 8-12 1/8	18 x 8-12 1/8
3.4 Caster wheels - diameter x width		---	---	---
3.5 Number of wheels - front / rear ((x) = drive wheel)		2 / 1(x)	2 / 1(x)	2 / 1(x)
3.6 Wheel track front		35.1" (865mm)	36.2" (920mm)	36.2" (920mm)
3.7 Wheel track rear		0	0	0
General dimensions	4.1 Mast tilt - forward / backward	<i>See mast specification chart</i>		
	4.2 Mast collapsed height	<i>See mast specification chart</i>		
	4.3 Mast free lift	<i>See mast specification chart</i>		
	4.4 Mast fork elevated height	<i>See mast specification chart</i>		
	4.5 Mast overall extended height	<i>See mast specification chart</i>		
	4.6 Base lift	-	-	-
	4.7 Overhead guard height	87.4" (2220mm) ²	87.4" (2220mm) ²	87.4" (2220mm) ²
	4.8 Operator seat height / stand height	ca. 41.7" (1060mm)	ca. 41.7" (1060mm)	ca. 41.7" (1060mm)
	4.9 Control handle height (walk behind units)	---	---	---
	4.10 Base leg height	---	---	---
	4.11 Special free lift	---	---	---
	4.15 Fork lowered height	---	---	---
	4.19 Total truck length	121.1" (3080mm) <i>***</i>	121.6" (3088mm) <i>***</i>	121.6" (3088mm) <i>***</i>
	4.20 Truck length to the back of the fork shank	81.9" (2080mm) <i>***</i>	82.2" (2088mm) <i>***</i>	82.2" (2088mm) <i>***</i>
	4.21 Truck overall width	40.2" (1020mm)	45.7" (1160mm)	45.7" (1160mm)
	4.22 Fork specifications - width x thickness x length (<i>stainless steel plated</i>)	4.2" x 1.6" x 39.4" (106mm x 41mm x 1000mm)	4.2" x 1.8" x 39.4" (106mm x 46mm x 1000mm)	4.2" x 1.8" x 39.4" (106mm x 46mm x 1000mm)
	4.23 Hook type fork class	ITA Class 2 (ISO 2B)	ITA Class 2 (ISO 2B)	ITA Class 2 (ISO 2B)
	4.24 Fork carriage width	37.4" (950mm)	37.4" (950mm)	37.4" (950mm)
	4.25 Maximum overall fork spread - manually adjustable	---	---	---
	4.26 Base leg opening	---	---	---
	4.28 Mast reach	---	---	---
4.29 Side shift (non standard option)	---	---	---	
4.31 Minimum under clearance	2.9" (75mm)	2.9" (75mm)	2.9" (75mm)	
4.32 Under clearance between the wheel base	3.5" (90mm)	3.5" (90mm)	3.5" (90mm)	
4.33 Aisle requirements with 39.4" long x 47.2" wide load (1000mm x 1200mm)	135.0" (3430mm) <i>***</i>	135.4" (3440mm) <i>***</i>	135.4" (3440mm) <i>***</i>	
4.34 Aisle requirements with 47.2" long x 31.5" wide load (1200mm x 800mm)	139.8" (3511mm) <i>***</i>	140.2" (3560mm) <i>***</i>	140.2" (3560mm) <i>***</i>	
4.35 Turning radius	69.3" (1760mm)	69.3" (1760mm)	69.3" (1760mm)	
4.37 Truck length including the base legs	---	---	---	
Performance	5.1 Travel speed - with / without load	8.4/8.8mph (13.5/14.2 km/h)	8.1/8.7mph (13.0/14.0 km/h)	7.8/8.6mph (12.5/13.8 km/h)
	5.2 Lift speed - with / without load	13.4/17.3 in/s (0.34/0.44m/s)	13.0/17.3 in/s (0.33/0.44m/s)	12.2/15.7 in/s (0.31/0.40m/s)
	5.3 Lower speed - with / without load	19.7/15.7 in/s (0.5/0.4m/s)	19.7/15.7 in/s (0.5/0.4m/s)	19.7/15.7 in/s (0.5/0.4m/s)
	5.6 Maximum towing capacity - with / without load	--- - 3687 lb/ff (--- -5000N)	--- - 3687 lb/ff (--- -5000N)	--- - 3687 lb/ff (--- -5000N)
	5.8 Gradient - with / without load	11 / 18	10 / 15	10 / 15
5.10 Brake system	Hydraulic	Hydraulic	Hydraulic	
Motors	6.1 Drive motor performance - S2 60 min.	10.1HP (7.5KW)	10.1HP (7.5KW)	10.1HP (7.5KW)
	6.2 Hydraulic motor performance - S3 15%	8.7HP (6.5KW)	8.7HP (6.5KW)	8.7HP (6.5KW)
	6.3 Battery according to DIN 43531/ 35 / 36 A, B, C, NO	NO	NO	NO
	6.4 Battery specification - V / AH / tank #	80V / 420-465AH / 148A	80V / 420-465AH / 148A	80V / 420-465AH / 148A
	6.5 Minimum battery weight	2618lb (1190kg)	2618lb (1190kg)	2618lb (1190kg)
	6.6 Energy usage after VDI-cycle	---	---	---
Others	8.1 Drive system	Frequency controller	Frequency controller	Frequency controller
	8.2 Attachment hydraulic working pressure	2900PSI (200bar)	2900PSI (200bar)	2900PSI (200bar)
	8.4 Noise level according to EN 12053	ca. 72 dBA	ca. 72 dBA	ca. 72 dBA

¹) Specification based on truck with DFFM mast, 4.2 = 87.6" (2225mm) without side-shift
²) with all weather cabin and closed roof ad 1.2" (30mm)

^{*}) Trucks with a TFFM mast, ad 2.6" (65mm)
^{**}) Trucks with side-shift ad 2.2" (55mm)

Model: M-716-3EEEx/ASM (long wheel base)

Mast type	4.2 Mast closed height	4.4 Fork elevated height	4.5 Overall extended height (with 36" = 915mm lbr)	4.3 / 4.6 Free Lift	4.1 Mast Tilt (forward / backward)
DFSM <i>(Two stage, no free lift)</i>	82.7" (2100mm)	125.0" (3175mm)	161.0" (4090mm)	5.9" (150mm)	2° / 3°
	87.6" (2225mm)	134.8" (3425mm)	170.9" (4340mm)	5.9" (150mm)	2° / 3°
DFFM <i>(Two stage, with free lift)</i>	82.7" (2100mm)	125.0" (3175mm)	161.0" (4090mm)	57.5" (1460mm)	2° / 3°
	87.6" (2225mm)	134.8" (3425mm)	170.9" (4340mm)	62.4" (1585mm)	2° / 3°
TFFM <i>(Three stage, with free lift)</i>	82.7" (2100mm)	180.5" (4585mm)	216.5" (5500mm)	57.5" (1460mm)	1° / 2°
	87.6" (2225mm)	191.3" (4860mm)	227.4" (5775mm)	62.4" (1585mm)	1° / 2°

Model: M-718-3EEEx/ASM (long wheel base)

Mast type	4.2 Mast closed height	4.4 Fork elevated height	4.5 Overall extended height (with 36" = 915mm lbr)	4.3 / 4.6 Free Lift	4.1 Mast Tilt (forward / backward)
DFSM <i>(Two stage, no free lift)</i>	82.7" (2100mm)	122.0" (3100mm)	158.1" (4015mm)	5.9" (150mm)	2° / 3°
	87.6" (2225mm)	131.9" (3350mm)	167.9" (4265mm)	5.9" (150mm)	2° / 3°
DFFM <i>(Two stage, with free lift)</i>	82.7" (2100mm)	122.0" (3100mm)	158.1" (4015mm)	57.5" (1460mm)	2° / 3°
	87.6" (2225mm)	131.9" (3350mm)	167.9" (4265mm)	62.4" (1585mm)	2° / 3°
TFFM <i>(Three stage, with free lift)</i>	82.7" (2100mm)	180.5" (4585mm)	216.5" (5500mm)	57.5" (1460mm)	1° / 2°
	87.6" (2225mm)	191.3" (4860mm)	227.4" (5775mm)	62.4" (1585mm)	1° / 2°

Model: M-720-3EEEx/ASM (long wheel base)

Mast type	4.2 Mast closed height	4.4 Fork elevated height	4.5 Overall extended height (with 36" = 915mm lbr)	4.3 / 4.6 Free Lift	4.1 Mast Tilt (forward / backward)
DFSM <i>(Two stage, no free lift)</i>	82.7" (2100mm)	122.0" (3100mm)	158.1" (4015mm)	5.9" (150mm)	2° / 3°
	87.6" (2225mm)	131.9" (3350mm)	167.9" (4265mm)	5.9" (150mm)	2° / 3°
DFFM <i>(Two stage, with free lift)</i>	82.7" (2100mm)	122.0" (3100mm)	158.1" (4015mm)	57.5" (1460mm)	2° / 3°
	87.6" (2225mm)	131.9" (3350mm)	167.9" (4265mm)	62.4" (1585mm)	2° / 3°
TFFM <i>(Three stage, with free lift)</i>	82.7" (2100mm)	180.5" (4585mm)	216.5" (5500mm)	57.5" (1460mm)	1° / 2°
	87.6" (2225mm)	191.3" (4860mm)	227.4" (5775mm)	62.4" (1585mm)	1° / 2°

Standard equipment & features:

- Maintenance free ASM-AC drive and hydraulic motors
- Fully programmable performance characteristics
- Dual overheating protection with speed reduction and disconnect
- Driver impulse control
- Regenerative braking system
- Hydraulic power steering
- Anti static package
- Conductive tires and wheels
- Stainless steel plated forks (brass optional)
- EEx Hour meter & battery state of charge combo
- Load backrest, 36" (915mm) high from the top of the forks
- Clear view mast
- Air horn
- Parking brake
- Startup diagnostic
- Locked battery connectors
- Automatic travel speed reduction when lifting the mast
- Multiple disc break system
- Operator, owners and spare parts manuals

Optional equipment & features:

- Brass plated forks (standard for US deliveries)
- EEx Side-shift (other attachments also available)
- Brass bumpers
- All weather cabin
- Closed overhead guard with safety glass window
- Alternative fork lengths
- Offshore anti corrosion package
- EEx Backup Alarm
- EEx Work lights (front and or back)
- Turning signal and brake lights
- EEx Strobe light
- Fire extinguisher
- Windshield & windshield wipers
- Custom mast elevations
- Custom paint color
- Turtle speed switch
- Lift limit switch with bypass
- Crane lugs
- Pneumatic tires (up to 3520lb = 1600kg capacity)